

Please check the examination details below before entering your candidate information

Candidate surname

Other names

Centre Number

Candidate Number

| | | | | |
|--|--|--|--|--|
| | | | | |
|--|--|--|--|--|

| | | | |
|--|--|--|--|
| | | | |
|--|--|--|--|

Pearson Edexcel International GCSE

Time 2 hours

Paper
reference

4MA1/2F

Mathematics A

PAPER 2F

Foundation Tier



You must have: Ruler graduated in centimetres and millimetres, protractor, pair of compasses, pen, HB pencil, eraser, calculator. Tracing paper may be used.

Total Marks

Instructions

- Use **black** ink or ball-point pen.
- **Fill in the boxes** at the top of this page with your name, centre number and candidate number.
- Answer **all** questions.
- Without sufficient working, correct answers may be awarded no marks.
- Answer the questions in the spaces provided
– *there may be more space than you need.*
- **Calculators may be used.**
- You must **NOT** write anything on the formulae page.
Anything you write on the formulae page will gain NO credit.

Information

- The total mark for this paper is 100.
- The marks for **each** question are shown in brackets
– *use this as a guide as to how much time to spend on each question.*

Advice

- Read each question carefully before you start to answer it.
- Check your answers if you have time at the end.

Turn over ►

P69202A

©2022 Pearson Education Ltd.

L:1/1/1/1/



Pearson

International GCSE Mathematics
Formulae sheet – Foundation Tier

$$\text{Area of trapezium} = \frac{1}{2}(a + b)h$$

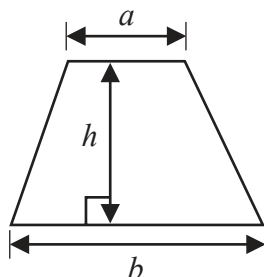

$$\text{Volume of prism} = \text{area of cross section} \times \text{length}$$

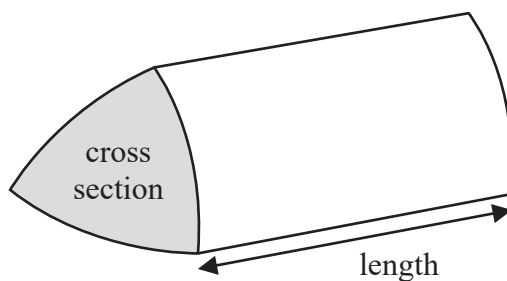

$$\text{Volume of cylinder} = \pi r^2 h$$

$$\text{Curved surface area of cylinder} = 2\pi r h$$

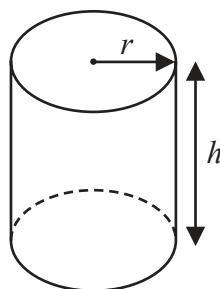

DO NOT WRITE IN THIS AREA

DO NOT WRITE IN THIS AREA

DO NOT WRITE IN THIS AREA



Answer ALL TWENTY SIX questions.

Write your answers in the spaces provided.

You must write down all the stages in your working.

- 1 The diagram shows a square and its diagonals.

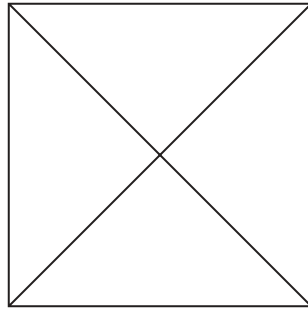

- (a) Shade $\frac{1}{4}$ of the square.

(1)

Here is a rhombus.

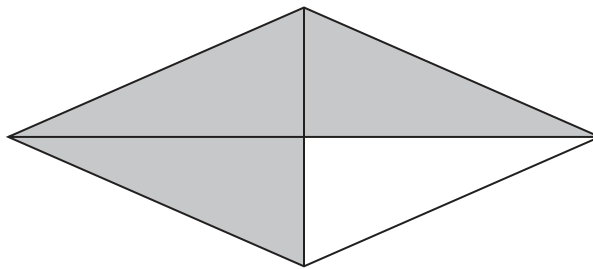

- (b) What fraction of the rhombus is shaded?

.....
(1)

- (c) Write 0.9 as a fraction.

.....
(1)

(Total for Question 1 is 3 marks)



2 Here is a list of numbers.

3 8 9 14 23 28 30

(a) From the numbers in the list, write down

(i) a cube number

.....
(1)

(ii) a factor of 70

.....
(1)

(iii) a multiple of 6

.....
(1)

(iv) a prime number.

.....
(1)

Here is a number machine.

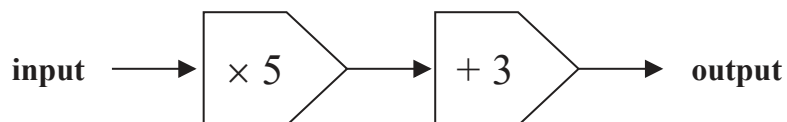

(b) Work out the input when the output is 108

.....
(2)

(Total for Question 2 is 6 marks)



- 3 The diagram shows a fair 8-sided spinner.

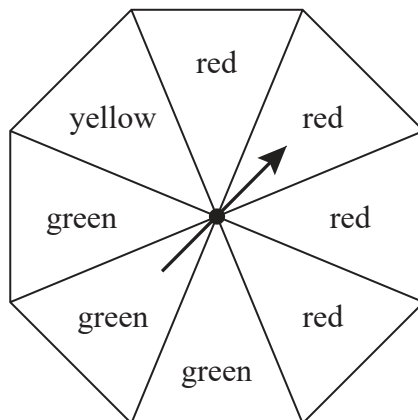

Hollie is going to spin the spinner once.

impossible unlikely evens likely certain

- (a) Write down the word from the box above that best describes the likelihood that the spinner will land on

(i) yellow

.....
(1)

(ii) red.

.....
(1)

- (b) On the probability scale below, mark with a cross (×) the probability that the spinner will land on blue.

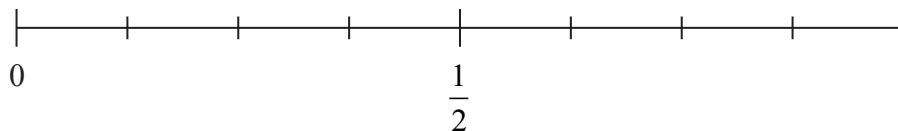

(1)

(Total for Question 3 is 3 marks)



- 4 The table below shows the maximum recorded temperature and the minimum recorded temperature on one day in each of four countries.

| Country | Maximum recorded temperature | Minimum recorded temperature |
|---------|------------------------------|------------------------------|
| Morocco | 19°C | 11°C |
| Qatar | 21°C | 18°C |
| Finland | -19°C | -28°C |
| Canada | 8°C | -40°C |

- (a) Which country has the highest maximum recorded temperature?

.....
(1)

- (b) Work out the difference between the maximum recorded temperature in Finland and the minimum recorded temperature in Finland.

..... °C
(1)

On the same day, the minimum recorded temperature in Japan is 15°C lower than the minimum recorded temperature in Morocco.

- (c) Work out the minimum recorded temperature in Japan.

..... °C
(1)

(Total for Question 4 is 3 marks)



- 5 The diagram shows points A and B marked on a grid of squares.

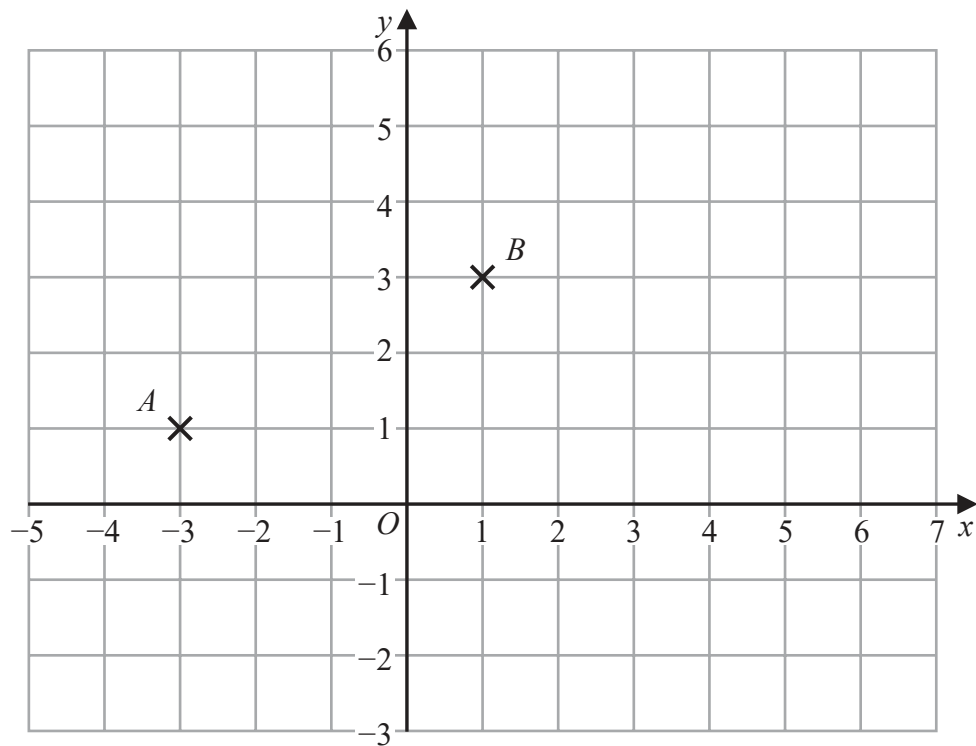

- (a) On the grid, draw the line with equation $y = -2$

(1)

M is the midpoint of AB

- (b) Find the coordinates of M

(.....,)
(2)

D is the point with coordinates $(5, d)$ where $d > 0$
The triangle ABD is an isosceles triangle.

- (c) Find the value of d

$d =$
(1)

(Total for Question 5 is 4 marks)



6 Here are nine shapes drawn on a grid of squares.

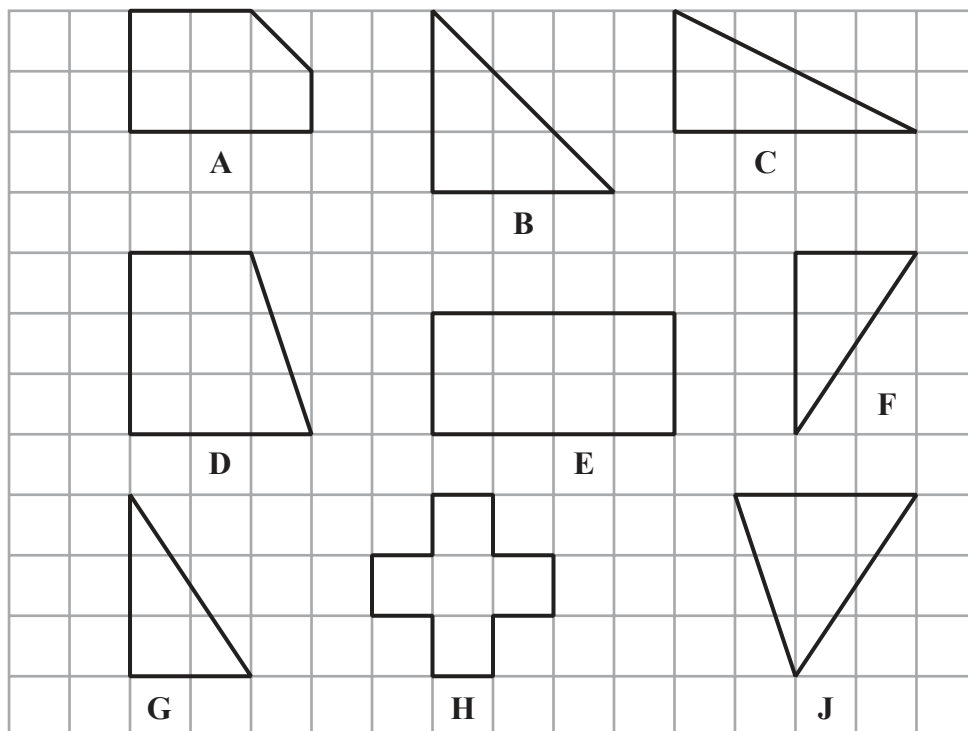

Shape **D** is a quadrilateral.

(a) What is the mathematical name of this quadrilateral?

.....
(1)

One of the shapes is congruent to shape **G**

(b) Write down the letter of this shape.

.....
(1)

(c) Write down the order of rotational symmetry of shape **H**

.....
(1)

(d) How many lines of symmetry has shape **E**?

.....
(1)

(Total for Question 6 is 4 marks)



7 $\frac{3}{8}$ of the members of a squash club are children.

$\frac{5}{6}$ of these children are right-handed.

What fraction of the members of the squash club are right-handed children?

Give your answer as a fraction in its simplest form.

Show your working clearly.

.....
(Total for Question 7 is 3 marks)

8 By writing each value correct to one significant figure, work out an estimate for the value of

$$\frac{8.23 \times 181}{0.482}$$

Show your working clearly.

.....
(Total for Question 8 is 3 marks)



9 The diagram shows triangle ABD

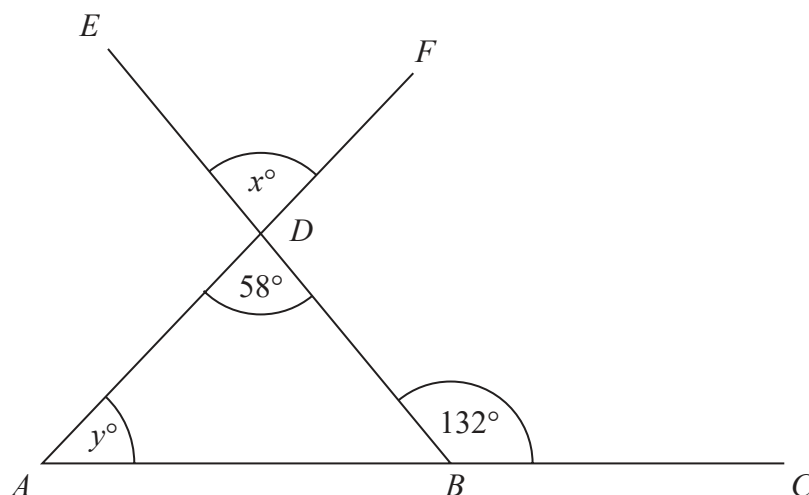

Diagram NOT accurately drawn

ABC , BDE and ADF are straight lines.

angle $CBD = 132^\circ$ angle $ADB = 58^\circ$

(a) (i) Write down the value of x

$x = \dots\dots\dots$

(ii) Give a reason for your answer.

(2)

(b) Work out the value of y

$y = \dots\dots\dots$

(2)

(Total for Question 9 is 4 marks)



11 Here is a sequence of patterns made from counters.



Pattern
number 1



Pattern
number 2



Pattern
number 3

(a) In the space below, draw Pattern number 4

(1)

(b) Complete the table.

| | | | | | |
|---------------------------|---|---|---|---|---|
| Pattern number | 1 | 2 | 3 | 4 | 5 |
| Number of counters | 3 | 6 | 9 | | |

(1)

(c) Work out the number of counters in Pattern number 10

(1)

Sven has exactly 70 counters.

(d) Can Sven make Pattern number 25 using his 70 counters?

Tick the appropriate box below.

Yes

No

Give a reason for your answer.

(1)

(Total for Question 11 is 4 marks)



DO NOT WRITE IN THIS AREA

DO NOT WRITE IN THIS AREA

DO NOT WRITE IN THIS AREA

12 The diagram shows a box **B** and a carton **C**

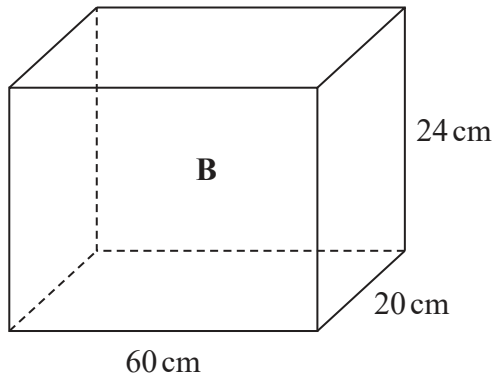
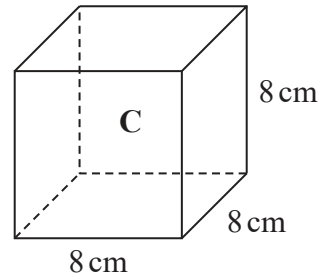

Diagram **NOT** accurately drawn



The box **B** is in the shape of a cuboid.
Each carton **C** is in the shape of an 8 cm cube.

Martha is going to put as many of the cartons as possible into the box.
She has enough cartons to do this.

Martha will then fill the remaining space inside the box with packing material.

Work out the volume of the space inside the box that Martha will fill with packing material.

..... cm³

(Total for Question 12 is 5 marks)



13 Here is a conversion graph to change between Canadian dollars and pounds (£)

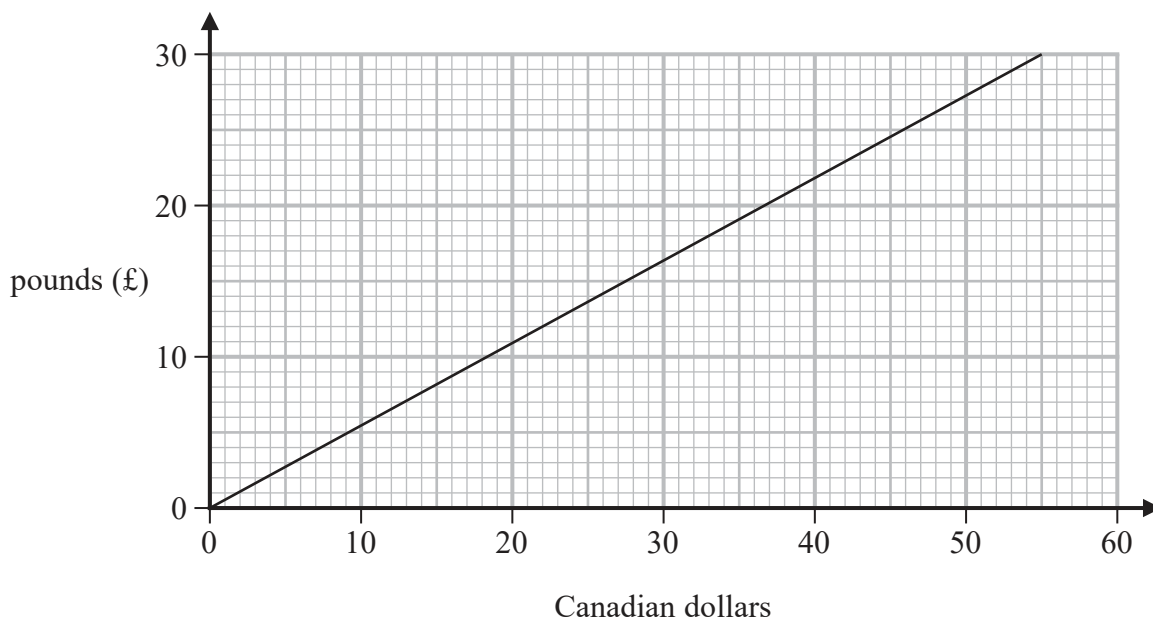

(a) Use the graph to change

(i) 46 Canadian dollars to pounds (£)

£.....

(ii) £10 to Canadian dollars.

..... Canadian dollars
(2)

Alana is on holiday in London and is going to Paris.
She is going to book a hotel in Paris.
She knows that

$$1 \text{ pound (£)} = 1.2 \text{ euros}$$

(b) Change 528 euros to Canadian dollars.

..... Canadian dollars
(3)

(Total for Question 13 is 5 marks)



DO NOT WRITE IN THIS AREA

DO NOT WRITE IN THIS AREA

DO NOT WRITE IN THIS AREA

14 Iman walked for 3 hours 15 minutes.
He walked a distance of 18.2 kilometres.

Work out Iman's average speed for his walk.
Give your answer in km/h

..... km/h

(Total for Question 14 is 3 marks)



P 6 9 2 0 2 A 0 1 5 2 8

15 Here is a list of the ingredients needed to make 12 chocolate brownies.

| |
|---|
| <p>Chocolate brownies Ingredients for 12 brownies</p> <p>150 g flour 250 g chocolate spread 3 eggs</p> |
|---|

Thalia buys exactly enough of these ingredients to make 120 of these brownies.

1.5 kg of flour costs £1.30

500 g of chocolate spread costs £2.60

6 eggs cost £1.10

Thalia sells all 120 brownies at £0.40 each.

Work out the profit that she makes.

£.....

(Total for Question 15 is 5 marks)



DO NOT WRITE IN THIS AREA

DO NOT WRITE IN THIS AREA

DO NOT WRITE IN THIS AREA

16 (a) Expand and simplify $x(2x - 3) + 7(2x + 1) - 5$

.....
(3)

(b) Expand and simplify $(y + 4)(2 - y)$

.....
(2)

(c) Factorise fully $15b^5c - 35b^3c^9$

.....
(2)

(Total for Question 16 is 7 marks)



17 Show that $6\frac{3}{4} \div 2\frac{4}{7} = 2\frac{5}{8}$

DO NOT WRITE IN THIS AREA

DO NOT WRITE IN THIS AREA

DO NOT WRITE IN THIS AREA

(Total for Question 17 is 3 marks)



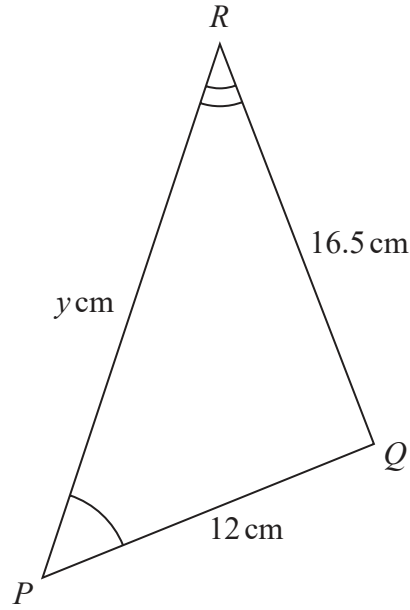
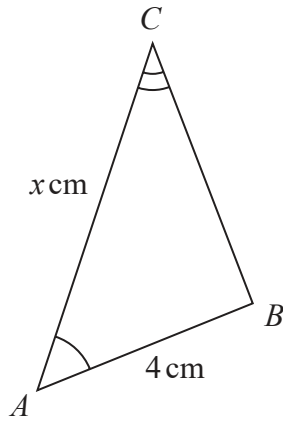

Diagram **NOT** accurately drawn

Triangle ABC is similar to triangle PQR

$AB = 4 \text{ cm}$ $PQ = 12 \text{ cm}$ $RQ = 16.5 \text{ cm}$ $AC = x \text{ cm}$ $PR = y \text{ cm}$

(a) Calculate the length of BC

..... cm
(1)

(b) Write down an expression for y in terms of x

$y =$
(1)

(Total for Question 18 is 3 marks)



19 Each side of a regular octagon has a length of 18 mm, correct to the nearest 0.5 mm

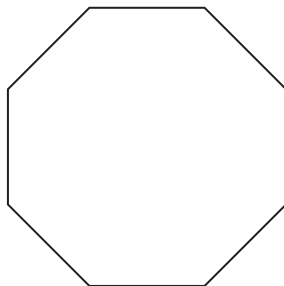

Diagram **NOT** accurately drawn

DO NOT WRITE IN THIS AREA

DO NOT WRITE IN THIS AREA

DO NOT WRITE IN THIS AREA

(a) Write down the lower bound of the length of each side of the octagon.

..... mm
(1)

(b) Write down the upper bound of the length of each side of the octagon.

..... mm
(1)

(Total for Question 19 is 2 marks)



20 The scale diagram shows the position on a map of a house, A

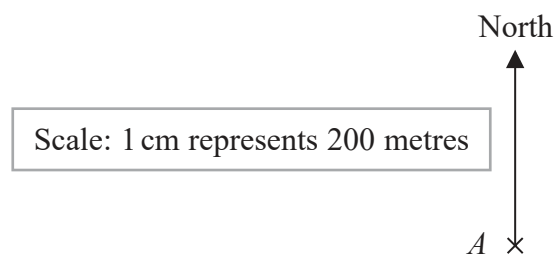

House C is on a bearing of 110° from A
The distance from A to C is 700 m

- (a) Mark the position of C on the diagram with a cross (\times)
Label your cross C

(3)

- (b) Write the scale of the map in the form $1:n$

1 :
(1)

(Total for Question 20 is 4 marks)



21 A bag contains only pink sweets, white sweets, green sweets and red sweets.

The table gives each of the probabilities that, when a sweet is taken at random from the bag, the sweet will be green or the sweet will be red.

| | | | | |
|--------------------|------|-------|-------|------|
| Sweet | pink | white | green | red |
| Probability | | | 0.2 | 0.35 |

The ratio

number of pink sweets : number of white sweets = 2 : 1

There are 28 red sweets in the bag.

Work out the number of white sweets in the bag.

(Total for Question 21 is 5 marks)



DO NOT WRITE IN THIS AREA

DO NOT WRITE IN THIS AREA

DO NOT WRITE IN THIS AREA

22 Find the lowest common multiple (LCM) of 28, 42 and 63
Show your working clearly.

.....
(Total for Question 22 is 3 marks)



P 6 9 2 0 2 A 0 2 3 2 8

- 23 The table gives information about the average house price in England in 2018 and in 2019

| Year | 2017 | 2018 | 2019 |
|-------------------------|------|---------|---------|
| Average house price (£) | | 228 314 | 231 776 |

- (a) Work out the percentage increase in the average house price from 2018 to 2019
Give your answer correct to one decimal place.

..... %
(2)

The average house price in 2019 was 7.7% greater than the average house price in 2017

- (b) Work out the average house price in 2017
Give your answer correct to 3 significant figures.

£
(3)

(Total for Question 23 is 5 marks)



24 The frequency table gives information about the number of points scored by a player.

| Number of points | Frequency |
|------------------|-----------|
| 0 | 13 |
| 1 | 17 |
| 2 | 8 |
| 3 | x |
| 4 | 11 |

The mean number of points scored is 2

Work out the value of x

$x = \dots\dots\dots$

(Total for Question 24 is 4 marks)



25 Solve the simultaneous equations

$$3x + 5y = 3.1$$

$$6x + 3y = 3.75$$

Show clear algebraic working.

$$x = \dots\dots\dots$$

$$y = \dots\dots\dots$$

(Total for Question 25 is 3 marks)

DO NOT WRITE IN THIS AREA

DO NOT WRITE IN THIS AREA

DO NOT WRITE IN THIS AREA



26 The diagram shows a regular 10-sided polygon, $ABCDEFGHIJ$

Diagram **NOT**
accurately drawn

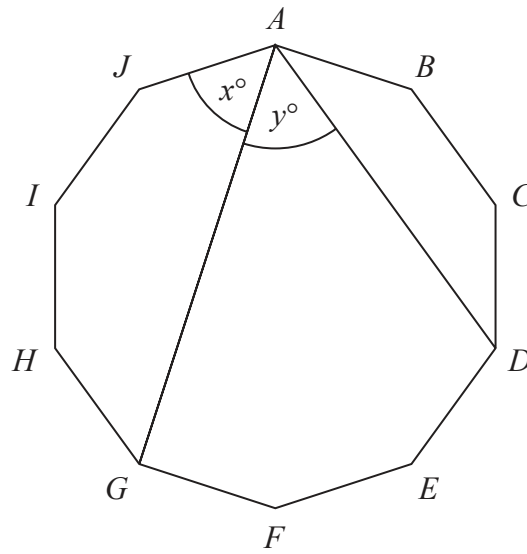

Show that $x = y$

(Total for Question 26 is 4 marks)

TOTAL FOR PAPER IS 100 MARKS

DO NOT WRITE IN THIS AREA



DO NOT WRITE IN THIS AREA

DO NOT WRITE IN THIS AREA

DO NOT WRITE IN THIS AREA

BLANK PAGE

